



Ultrapure water system HALIOS 40 ID



HALIOS lab water systems make your work as pleasant and comfortable as possible and maximize at the same time your lab productivity

The HALIOS 40 ID lab water series is modular designed and can be connected directly to tap water. With an external tank and a production rate of 40l/h it provides a high flexibility to adapt to your specific needs. Each system meets and exceeds ASTM type 1 and 2 standards. An integrated RO membrane guarantees a long durability of the following purification cartridges as well as a constant ideal ultrapure water quality for reproducible results of analysis. The compact unit can be easily integrated in the lab environment.



Features

- ✓ Reliable ultrapure water quality - ASTM type 1⁺ and 2
- ✓ Integrated dispenser
 - detachable and ergonomically shaped
 - rotatable and vertically adjustable
- ✓ Simple and economical change of the consumables
- ✓ Large and intuitive touchscreen
- ✓ Leak water detector
- ✓ Pressure reducer
- ✓ Data capture via USB
- ✓ Accurate, adjustable volume dispensing
- ✓ Dry-run protection
- ✓ External 30l tank with complete recirculation ensures the highest microbial purity
- ✓  ECO Mode to extend the cartridge life by up to 20%

System configuration

- Wide-range power supply 80-264V / 50-60Hz
- Housing with an easily accessible service cover
- Compact production unit fits easily into various free spaces in the lab
- Exchange of consumables within seconds due to quick-connect couplings
- Integrated pressure reducer for different inlet pressures
- Flow meter for an accurate volume dispensing
- Pressure sensor for monitoring of the working pressure and as a dry-running protection
- Two low-noise and durable pressure and recirculation pumps for the complete internal recirculation of all wetted parts up to the final dispensing valve
- RO membrane removes up to 99% of all impurities in the feed water
- Ultrapure water cartridge for the final removal of organics and remaining ions
- Up to three measuring cells for the exact measurement of the conductivity and temperature after each purification cartridge
- Flush valve for the effective cleaning of all wetted parts as well as an adjustable quality flush during stand-by
- Dispenser with microfiltration for the sterile ultrapure water withdrawal at the point of use
- External pure water tank with sloped bottom and pure water (type 2) outlet
- ECO Mode extends the cartridge life by up to 20%

Optional

- UV-unit (185|254nm) for the ultimate microbiological purity and TOC reduction
- Flushed and integrated ultrafiltration module for the retention of pyrogens, endotoxins, proteins and nucleases (DNases and RNases)
- Up to 4 external dispensers can be connected to one production unit

User interface

- Large and intuitive touchscreen
- Stored dispensing reports with all information ensure an absolute traceability of the water withdrawals
- Individual adjustment for displaying the conductivity (M Ω cm or μ S/cm)
- Multilevel conductivity and temperature monitoring for pure and ultrapure water, temperature compensated with stepless limit adjustments
- High-precision measuring with integrated reference resistors as well as deactivatable temperature compensation acc. to USP
- Leakage monitor with error message and automatic shut-off of the feed water supply
- Continuous surveillance of all relevant parameters and values incl. early reminders when a change of consumables is pending
- GLP-compliant data storage via USB



Integrated dispenser

- Ergonomic design for a one-handed operation
- All dosing functions can be easily executed with the rotary encoder at the dispensing handle
- For an even greater range the HALIOS handle can be detached and reattached with a simple hand movement



External 30,60 or 100l Tank

- Made of PE for a minimum release of extractables
- A smooth inner surface prevents biofilm formation
- A sterile overflow and an advanced vent filter with CO₂ Adsorber protecting your stored water against airborne contaminants
- Sloped bottom and circulation ensure the highest microbial purity



Feed water requirements

Feed water quality	Potable tap water
Conductivity at 25°C	< 2000µS/cm
Total organic carbon (TOC)	< 1ppm
Inlet pressure*	1 – 6bar
Temperature	5 – 35°C

Additional pretreatment units are available if the feed water is out of specs

Ultrapure water specifications (ASTM type 1)¹:

Resistivity (Conduct.) at 25°C ²	18.2MΩcm (0.055µS/cm)
Total Organic Carbon ³ (TOC)	≤ 2ppb (µg/l) ≤ 10ppb (w/o option – UV lamp)
Particle content ⁴	< 1/ml
Bacteria	< 0,01 CFU/ml ⁴ < 0,005 CFU/ml ⁵
Pyrogens (endotoxins) ⁵	< 0,001 EU/ml
RNases ⁵	< 0,004ng/ml
DNases ⁵	< 0,024pg/µl
Flow rate	Up to 2l/min

Pure water specifications in the tank (ASTM type 2)

Resistivity (Conduct.) at 25°C	> 10MΩcm (<0,1µS/cm)
TOC	≤ 30ppb (µg/l)
Performance	40l/h

¹ *The actual values may vary depending on the nature and concentration of the contaminants in the feed water*

² *Conductivity/resistivity can also be displayed non-temperature compensated as required by USP*

³ *In the appropriate operating conditions*

⁴ *With sterile filter capsule at the POU*

⁵ *With option – ultrafiltration module*

Technical data

Ambient temperature	+2 - 35°C
Supply voltage	90-240V / 50-60Hz
Connected load	120W
Connection size	R ¾"

Dimensions

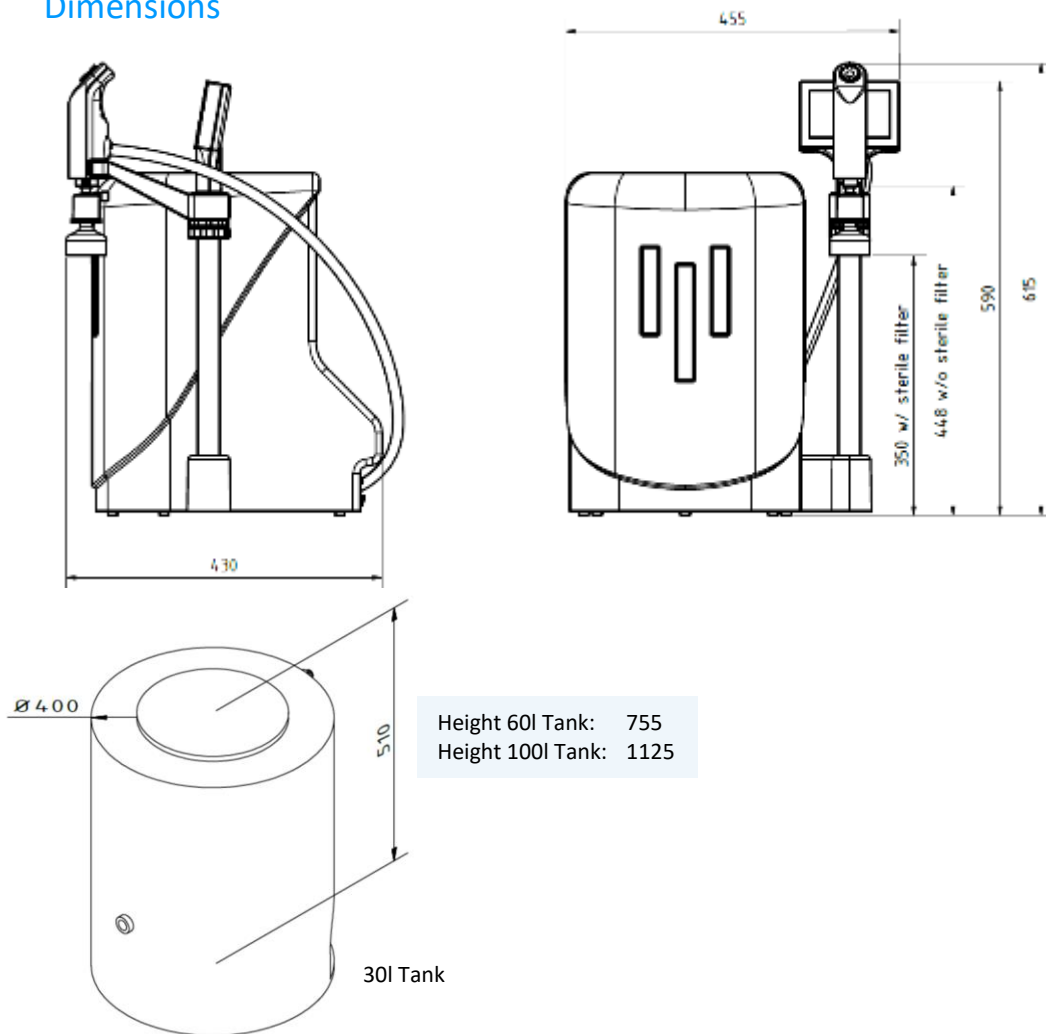

Ordering information

Lab water system

Catalogue Number

10000535

Description

Ultrapure water system HALIOS 40 ID

Accessories / options

10000101

Option – UV lamp 185 | 254nm

10000102

Option – Ultrafiltration module

10000105

Wall mount for production Unit HALIOS

10000367

Water softener MixMulti WEA 25
(pretreatment for poor feedwater)

10000374

Pretreatment unit HALIOS 40

10000302

Qualification documents HALIOS 40

Accessories / options

10000470	Pure water tank 30l incl. level sensor, circulation pump, tap, sterile overflow and vent filter
10000471	Pure water tank 60l incl. level sensor, circulation pump, tap, sterile overflow and vent filter
10000378	Pure water tank 100l incl. level sensor, circulation pump, tap, sterile overflow and vent filter
10000456	Option - UV tank disinfection for 30/60/100l tank
10000380	Option - Pressure outlet for 30/60/100l tank 120l/h at 3 bar
10000480	Option - External pressure pump 3m ³ /h at 27m
10000430	Disinfection kit HALIOS incl. one disinfectant

Consumables

10000252	Combi filter 5 µm + activated carbon - 10"
10000379	RO membrane 40l/h
10000107	Polishing cartridge HALIOS UPW 182
10000110	Replacement ultrafilter
10000108	Replacement UV-lamp 185 245nm
10000109	Sterile filter capsule 0.2µm
10000116	Sterile vent filter 0.2µm
10000431	Disinfectant HALIOS in a syringe (Disinfection kit necessary)